

Installation instructions
Montageanleitung
Notice de montage
Istruzioni di montaggio
Instrucciones de montaje
Montageaanwijzing

METTLER TOLEDO

METTLER TOLEDO
Quick Pit PFA

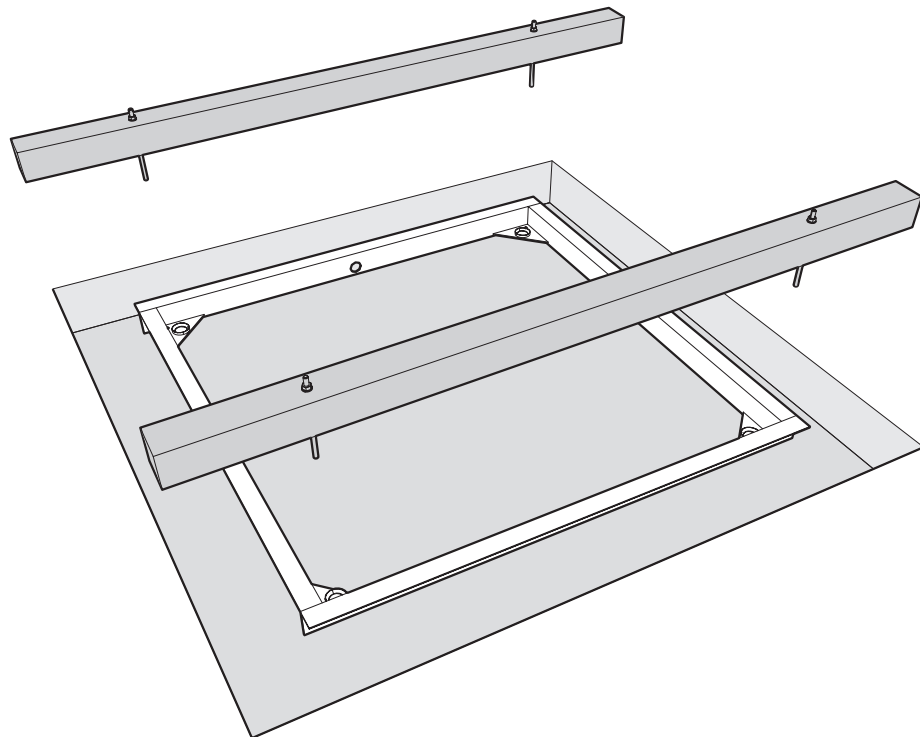

www.mt.com/support

ServiceXXL

Tailored Services

Congratulations on choosing the quality and precision of METTLER TOLEDO. Proper use according to these installation instructions and regular calibration and maintenance by our factory-trained service team ensure dependable and accurate operation, protecting your investment. Contact us about a ServiceXXL agreement tailored to your needs and budget.

We invite you to register your product at www.mt.com/productregistration so we can contact you about enhancements, updates and important notifications concerning your product.

Contents

	Page
English	4
Deutsch	6
Français.....	8
Español	10
Italiano	12
Nederlands.....	14

1 Determining location

1.1 Determining location of the weighing platform

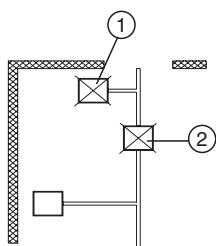

- Avoid areas near doors (1).
- Avoid high traffic areas (2).
- Protect the weighing platform against strong air movements.
- Load-bearing capacity of pit base:
min. 1500 kg / 25 cm²

1.2 Determining location of the weighing terminal

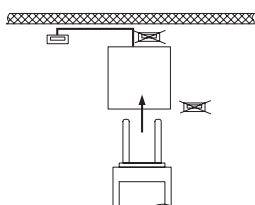

- Locate terminal for maximum visibility and easy access.
- Standard base-to-terminal cable length is 5 m.

2 Excavating pit

- Excavate pit to dimensions specified in table below:

Considerations:

- Optimal drain location areas are depicted on dimensional drawing (see part 4).
- There are 2 possible cable conduit locations (see part 4).
- Cable conduit diameter min. 50 mm.
- Do not use right-angled pipe, but 2 x 45°.

Type	Weighing platform dim.		Pit dimensions			Frame dimensions		
	Width _{wp}	Length _{wp}	Width	Length	Depth (c)	Width (b)	Length (a)	Height
PFA57x-DS	100	100	150	150	15	114	114	9
PFA57x-D	125	100	175	150	15	139	114	9
PFA57x-E	150	125	200	175	15	164	139	9
PFA57x-ES	150	150	200	200	15	164	164	9
PFA57x-G	200	150	250	200	15	214	164	9
PFA57x-F	70–200	40–150	Width _{wp} +50	Length _{wp} +50	15	Width _{wp} +14	Length _{wp} +14	9

Dimensions in cm

3 Preparing framework

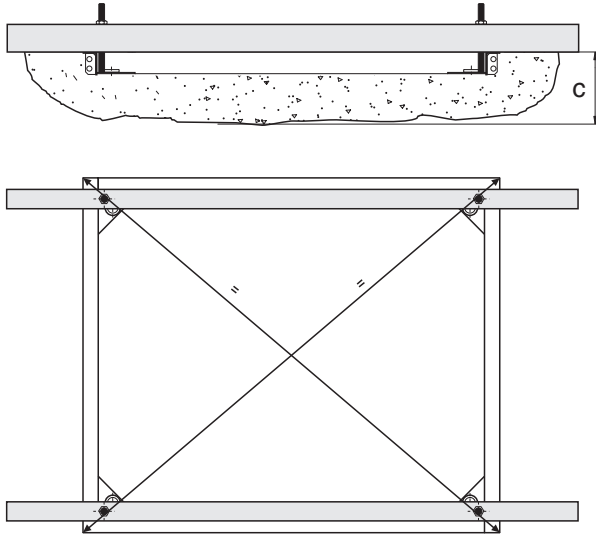

- Verify that the inside frame diagonal dimensions are equal.
- Fold out side wall anchors.
- Mount 4 x M10 threaded rods.
The threaded rods are included in the scope of delivery.
- Fasten the threaded rods to the wooden frame using the nuts.
- Position frame into pit.
- Level Quick Pit exactly using the threaded rods.

Note:
The frame must be exactly levelled.

4 Dimension drawings

Dry pit

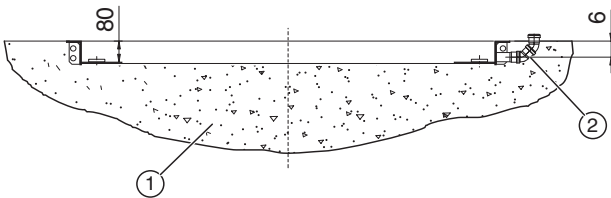

Wet pit

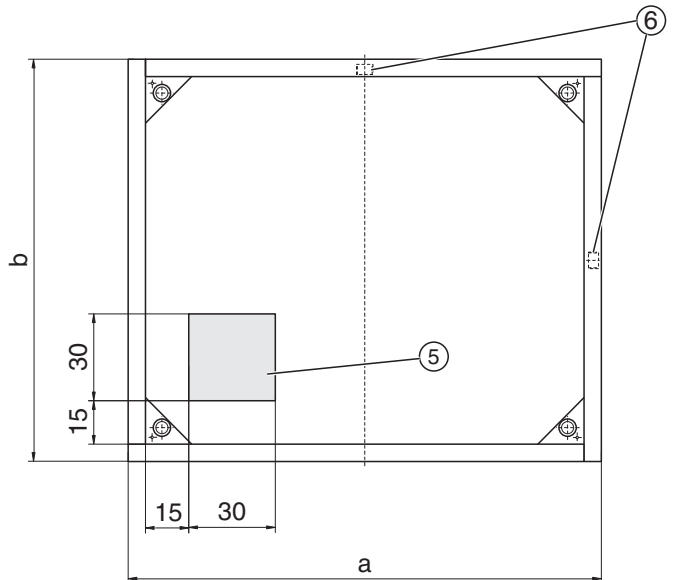
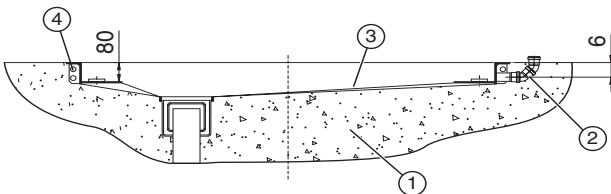

- 1 Concrete base, depth = approx. 15 cm
- 2 Cable conduit, two 45° pipes
- 3 Slope min. 4 %

- 4 Mounting possibility for iron rods as reinforcement
- 5 Drain area
- 6 2 possible cable conduit connections

1 Wahl des Aufstellorts

1.1 Standort der Wagebrucke bestimmen

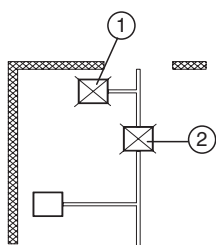

- Nicht in der Nahe von Turen (1) installieren.
- Nicht in verkehrsreichen Bereichen (2) installieren.
- Wagebrucke vor starken Luftbewegungen schutzen.
- Tragfahigkeit des Grubenbodens:
mind. 1500 kg / 25 cm²

1.2 Standort des Terminals bestimmen

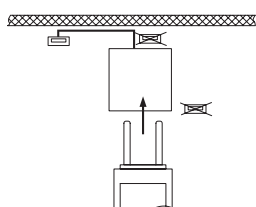

- Terminal so aufstellen, dass es gut zu erreichen ist.

Lange des Verbindungskabels fur das Terminal: 5 m

2 Rohgrube herstellen

- Rohgrube entsprechend dem Wagebrucken-Typ ausheben:

Folgende Punkte beachten:

- Die Position des Ablaufschachts den Mazeichnungen entnehmen (siehe Abschnitt 4).
- Es gibt 2 mogliche Positionen, um das Verbindungskabel anzuschlieen (siehe Abschnitt 4).
- Kabelkanaldurchmesser mind. 5 cm.
- Kein rechtwinkliges Rohr verwenden, sondern 2 x 45°.

Typ	Wagebruckenmae		Grubenmae			Rahmenmae		
	Breite _{Wb}	Lange _{Wb}	Breite	Lange	Tiefe (c)	Breite (b)	Lange (a)	Hohe
PFA57x-DS	100	100	150	150	15	114	114	9
PFA57x-D	125	100	175	150	15	139	114	9
PFA57x-E	150	125	200	175	15	164	139	9
PFA57x-ES	150	150	200	200	15	164	164	9
PFA57x-G	200	150	250	200	15	214	164	9
PFA57x-F	70–200	40–150	Breite _{Wb} +50	Lange _{Wb} +50	15	Breite _{Wb} +14	Lange _{Wb} +14	9

Mae in cm

3 Vorbereitung des Rahmens

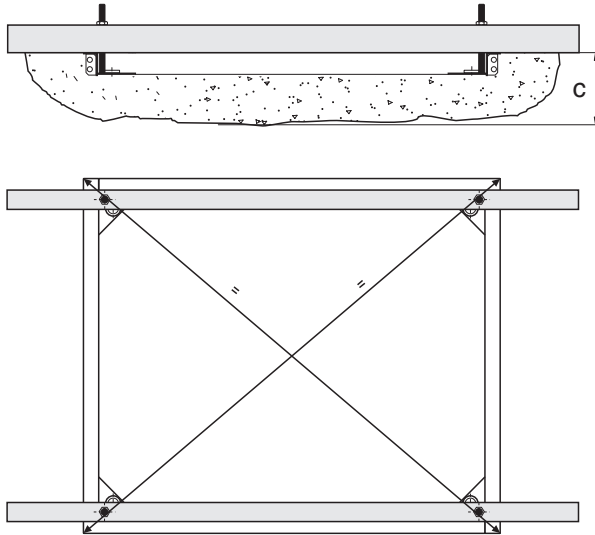

- Diagonale überprüfen.
- Seitliche Maueranker ausklappen.
- 4 x M10 Gewindestangen montieren.
Die Gewindestangen sind im Lieferumfang enthalten.
- Gewindestangen mit den Muttern auf dem Holzrahmen befestigen.
- Rahmen in die Rohgrube einhängen.
- Quick Pit mit Hilfe der Gewindestangen genau nivellieren.

Hinweis:

Der Grubenrahmen muss exakt nivelliert werden!

4 Maßzeichnungen

Trockengrube

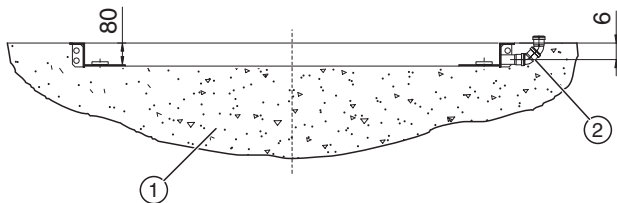

Nassgrube

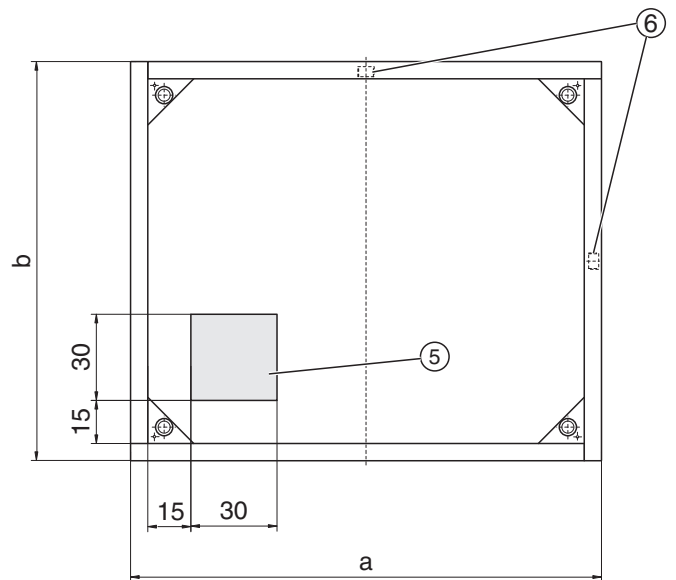
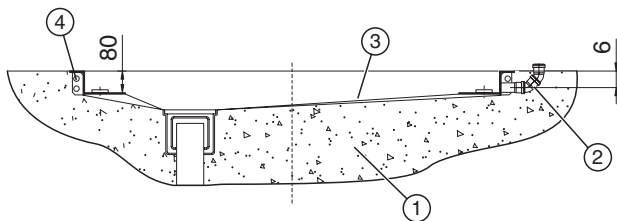

- | | |
|--|--|
| <ul style="list-style-type: none"> 1 Betonsockel, ca. 15 cm tief 2 Kabelkanal, zwei 45°-Rohre 3 Mindestens 4 % Gefälle | <ul style="list-style-type: none"> 4 Befestigungsmöglichkeit für Eisenstäbe zur Armierung 5 Bereich für den Ablauf 6 2 Anschlussmöglichkeiten Kabelkanal |
|--|--|

1 Déterminer l'emplacement

1.1 Déterminer l'emplacement de la plate-forme de pesage

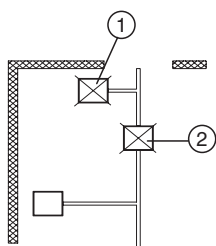

- Eviter des zones situées à proximité de portes (1).
- Eviter les zones à trafic intense (2).
- Protéger la plate-forme de pesage des mouvements d'air importants.
- Capacité portante du fond de la fosse:
min. 1500 kg / 25 cm²

1.2 Déterminer l'emplacement du terminal

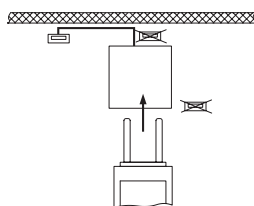

- Sélectionner un emplacement pour le terminal qui offre une visibilité maximale et un accès aisé.

La longueur de câble standard entre la base et le terminal est de 5 m.

2 Creuser la fosse

- Creuser la fosse aux dimensions spécifiées dans le tableau ci-dessous.

Considérations:

- Les zones optimales de placement des drains sont représentées sur le plan coté (voir partie 4).
- Il y a 2 emplacements possibles pour les conduits de câbles (voir partie 4).
- Diamètre du conduit à câbles min. 50 mm.
- N'utiliser pas de coudes à angle droit, mais 2 x 45°.

Type	Dimensions plate-forme		Dimensions fosse			Dimensions cadre		
	Largeur _{wb}	Longueur _{pf}	Largeur	Longueur	Prof. (c)	Largeur (b)	Longueur (a)	Haut.
PFA57x-DS	100	100	150	150	15	114	114	9
PFA57x-D	125	100	175	150	15	139	114	9
PFA57x-E	150	125	200	175	15	164	139	9
PFA57x-ES	150	150	200	200	15	164	164	9
PFA57x-G	200	150	250	200	15	214	164	9
PFA57x-F	70–200	40–150	Largeur _{pf} +50	Longueur _{pf} +50	15	Largeur _{pf} +14	Longueur _{pf} +14	9

Dimensions en cm

3 Préparer le cadre

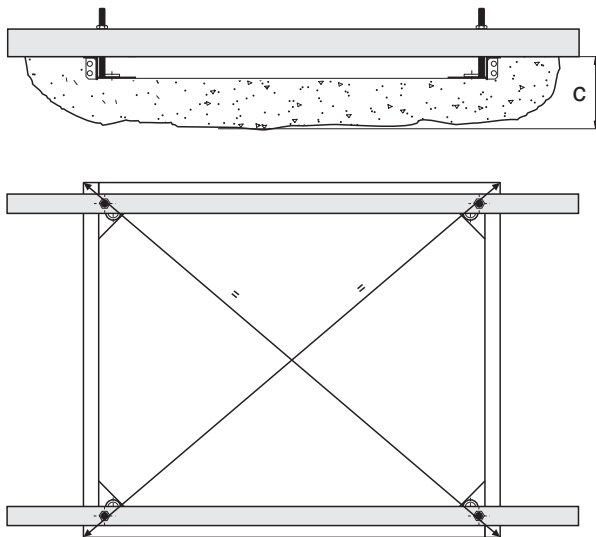

- Vérifier que les dimensions diagonales intérieures sont identiques.
- Déployer l'ancrage mural latéral.
- Monter les 4 tiges filetées M10.
Les tiges filetées sont comprises dans la livraison.
- Fixer les tiges filetées avec les boulons sur le cadre en bois.
- Positionner le cadre dans la fosse.
- Mettre Quick Pit exactement à niveau à l'aide des tiges filetées.

Note:

Le cadre doit être mis exactement à niveau!

4 Plan coté

Fosse sèche

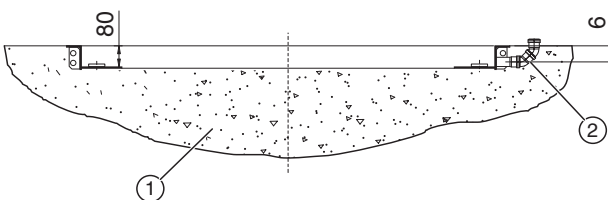

Fosse humide

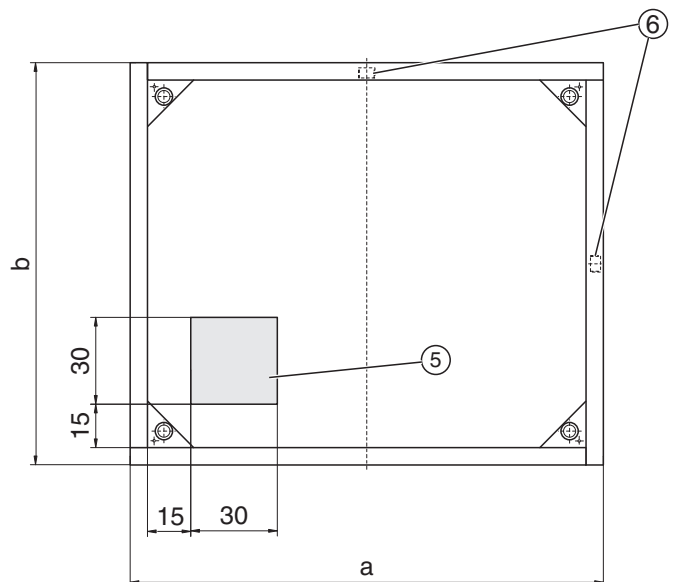
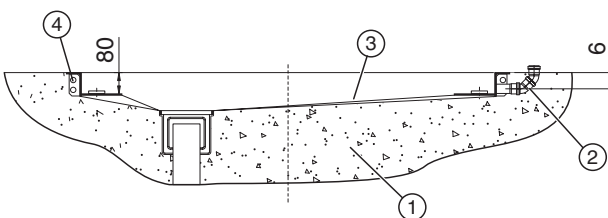

- 1 Base en béton, profondeur env. 15 cm
- 2 Conduit, deux coudes à 45°
- 3 Pente min. 4 %

- 4 Possibilité de fixation pour barres d'acier sur armature
- 5 Zone d'égouttage
- 6 2 emplacements possibles pour les conduits de câbles

1 Determinación del emplazamiento

1.1 Determinación del emplazamiento de la plataforma de pesada

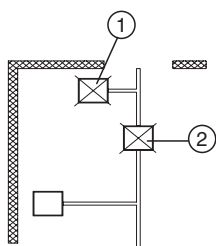

- Evitar las zonas cerca a las puertas (1).
- Evitar las zonas de mucho tráfico (2).
- Proteger la plataforma de pesada contra corrientes de aire fuertes.
- Capacidad de carga de la base del foso:
mín. 1500 kg / 25 cm²

1.2 Determinación del emplazamiento del terminal

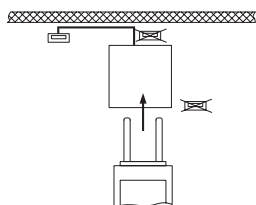

- Emplazar el terminal de modo que ofrezca máxima visibilidad y fácil acceso.
- Longitud del cable estándar base-terminal: 5 m

2 Excavación del foso

- Excavación del foso con las medidas especificadas en la tabla abajo.

Observaciones:

- Las zonas de emplazamiento para drenaje se describen en el dibujo de medidas (ver parte 4)
- Hay 2 maneras de colocar el conducto para cables (ver parte 4).
- Diámetro del conducto para cables: mín. 50 mm.
- No utilizar tubería en ángulo recto, sino 2 x 45°.

Tipo	Medidas plataforma		Medidas del foso			Medidas del marco		
	Anchura _{pf}	Longitud _{pf}	Anchura	Longitud	Prof. (c)	Anchura (b)	Longitud (a)	Altura
PFA57x-DS	100	100	150	150	15	114	114	9
PFA57x-D	125	100	175	150	15	139	114	9
PFA57x-E	150	125	200	175	15	164	139	9
PFA57x-ES	150	150	200	200	15	164	164	9
PFA57x-G	200	150	250	200	15	214	164	9
PFA57x-F	70-200	40-150	Anchura _{pf} +50	Longitud _{pf} +50	15	Anchura _{pf} +14	Longitud _{pf} +14	9

Dimensiones en cm

3 Preparación del armazón

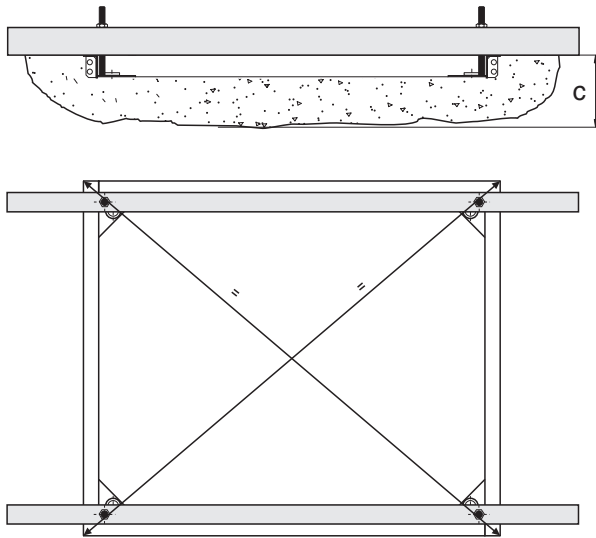

- Verificar que las medidas diagonales interiores del marco sean iguales
- Desplegar las patas laterales para empotrar.
- Montar las varas roscadas 4 x M10.
Las varas roscadas se incluyen en el volumen de suministro.
- Fijar las varas roscadas con las tuercas en el armazón de madera.
- Emplazar el marco en el foso.
- Nivelar exactamente el Quick Pit con ayuda de las varas roscadas.

Nota:
El bastidor debe estar exactamente nivelado!

4 Dibujo de medidas

Foso seco

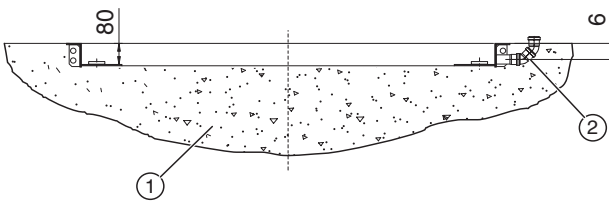

Foso húmedo

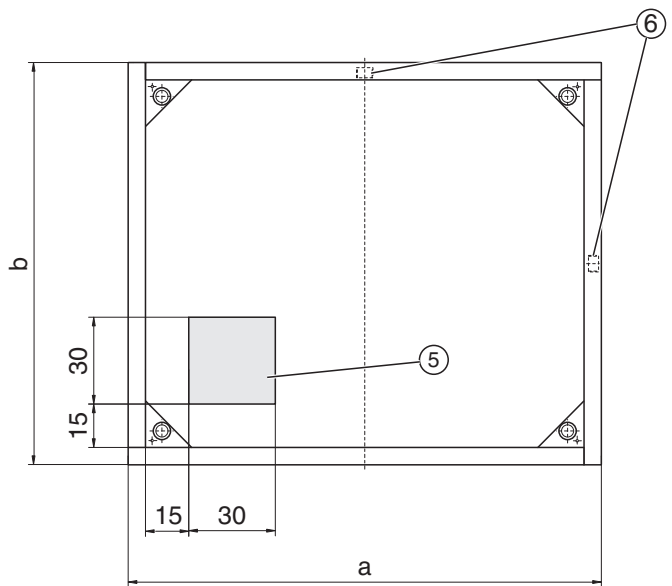
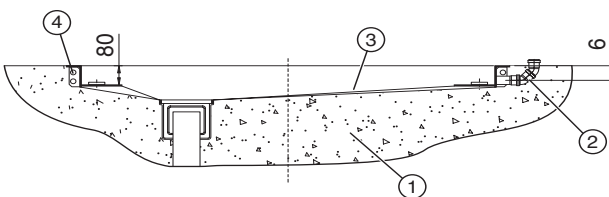

- 1 Base de concreto, prof. aprox. 15 cm
- 2 Conducto para cables, 2 x 45°
- 3 Plano inclinado mín. 4 %

- 4 Posibilidad de fijación de barras de hierro para la armadura
- 5 Zona de drenaje
- 6 2 maneras de colocar el conducto para cables

1 Determinazione della posizione d'installazione

1.1 Posizione d'installazione della piattaforma di pesata

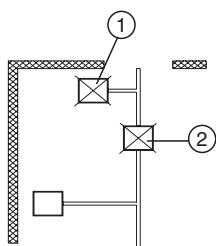

- Evitare le zone vicine alle porte (1).
- Evitare le zone ad alto traffico (2).
- Proteggere il terminale da forti correnti d'aria.
- Capacità di portata del carico della base della fossa:
min. 1500 kg / 25 cm²

1.2 Posizione d'installazione del terminale

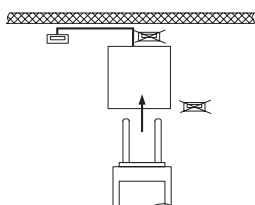

- Disporre il terminale in modo da avere la massima visibilità e facilità d'accesso.

La lunghezza standard del cavo tra base e terminale è di 5 m.

2 Scavo della fossa

- Scavare la fossa con le dimensioni specificate nella seguente tabella:

Considerazioni:

- Le zone per il posizionamento ottimale dello scarico dell'acqua sono mostrate sul disegno quotato (v. Parte 4).
- Le possibili posizioni per l'installazione del tubo per il cavo sono 2 (v. Parte 4).
- Diametro minimo del tubo per il cavo: 50 mm.
- Non usare tubi a gornito a 90°, ma 2 x 45°.

Tipo	Dimensione piattaforma		Dimensioni fossa			Dimensioni telaio		
	Largh. _{pf}	Lungh. _{pf}	Larghezza	Lungh.	Prof. (c)	Larghezza (b)	Lungh. (a)	Alt.
PFA57x-DS	100	100	150	150	15	114	114	9
PFA57x-D	125	100	175	150	15	139	114	9
PFA57x-E	150	125	200	175	15	164	139	9
PFA57x-ES	150	150	200	200	15	164	164	9
PFA57x-G	200	150	250	200	15	214	164	9
PFA57x-F	70–200	40–150	Largh. _{pf} +50	Lungh. _{pf} +50	15	Largh. _{pf} +14	Lungh. _{pf} +14	9

Dimensioni in cm

3 Preparazione del telaio

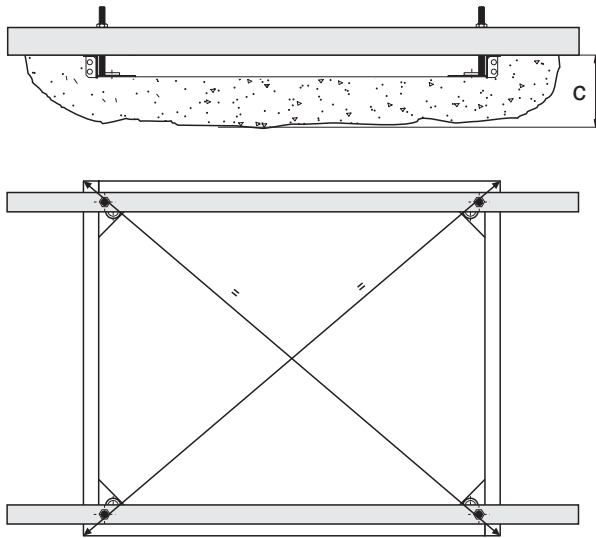

- Verificare che le lunghezze delle diagonali interne del telaio siano eguali.
- Ribaltare le staffe di ancoraggio a muro laterali.
- Installare 4 aste filettate M10.
Le aste filettate sono contenute nella dotazione di fornitura.
- Fissare le aste filettate sul telaio di legno con gli appositi dadi.
- Posizionare il telaio nella fossa.
- Mettere accuratamente in bolla Quick Pit con l'ausilio delle aste filettate.

Nota:
Il telaio dev'essere in bolla!

4 Disegno quotato

Fossa secca

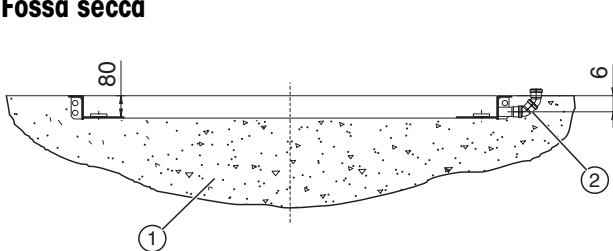

Fossa humida

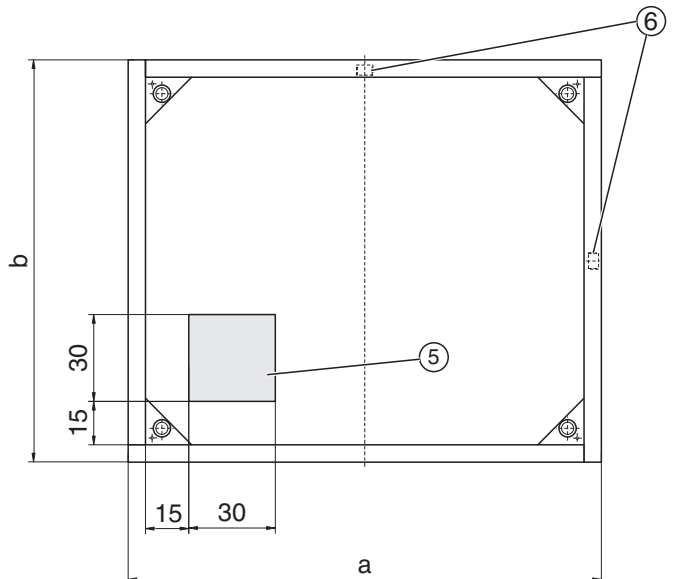
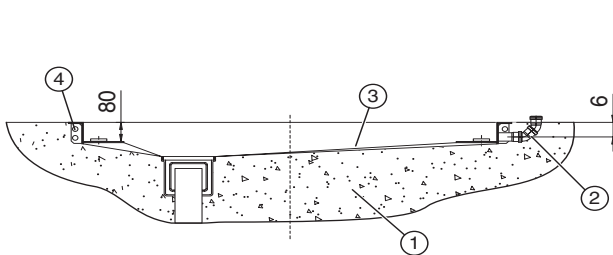

- 1 Base in cemento, profondità ca. 15 cm
- 2 Tubo cavo, 2 x 45°
- 3 Pendenza 4 % min.

- 4 Possibilità di fissaggio per barre di ferro a scopo di rinforzo
- 5 Zona per lo scarico dell'acqua
- 6 2 possibili posizioni per l'installazione del tubo cavo

1 Bepaal de locatie

1.1 Bepaal de locatie van het weegplateau

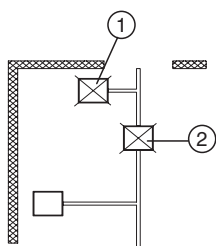

- Vermijd locaties in de buurt van deuren (1).
- Vermijd locaties met veel verkeer (2).
- Bescherm het weegplateau tegen sterke lucht-bewegingen.
- Draagvermogen van de putbodem:
mind. 1500 kg / 25 cm²

1.2 Bepaal de locatie van de terminal

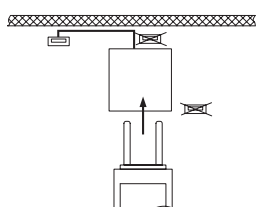

- Plaats de terminal zodanig dat u een goed overzicht en gemakkelijk toegang hebt.

Standaardlengte van kabel tussen plateau en terminal:
5 m

2 Graaf de put uit

- Graaf de put volgens de afmetingen in de onderstaande tabel uit.

Voorwaarden:

- Locaties voor de afvoer zijn afgebeeld op de maatschets (zie deel 4)
- Er zijn 2 locaties mogelijk voor het kabelkanaal (zie deel 4).
- Diameter kabelkanaal min. 50 mm.
- Gebruik geen haakse bocht, maar 2 x 45°.

Type	Afmetingen weegplateau		Afmetingen put			Afmetingen frame		
	Breedte _{wp}	Lengte _{wp}	Breedte	Lengte	Diepte (c)	Breedte (b)	Lengte (a)	Hoogte
PFA57x-DS	100	100	150	150	15	114	114	9
PFA57x-D	125	100	175	150	15	139	114	9
PFA57x-E	150	125	200	175	15	164	139	9
PFA57x-ES	150	150	200	200	15	164	164	9
PFA57x-G	200	150	250	200	15	214	164	9
PFA57x-F	70–200	40–150	Breedte _{wp} +50	Lengte _{wp} +50	15	Breedte _{wp} +14	Lengte _{wp} +14	9

Afmetingen in cm

3 Bereid het frame voor

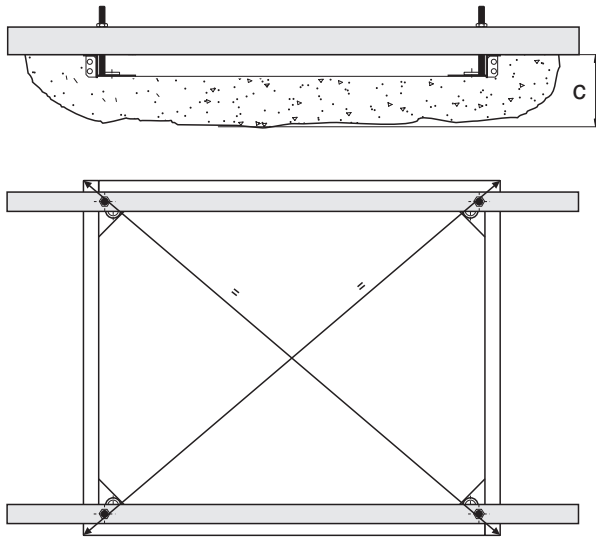

- Controleer of de diagonale binnenmaten van het frame gelijk zijn.
- Klap de muurankers aan de zijkant uit.
- Breng 4 x M10 draadstangen aan. De draadstangen zijn bij de levering inbegrepen.
- Bevestig de draadstangen met de moeren aan het houten frame.
- Plaats het frame in de put.
- Lijn de frame met behulp van de draadstangen nauwkeurig horizontaal uit.

Opmerking:

Het frame moet nauwkeurig waterpas staan!

4 Maatschets

Droge put

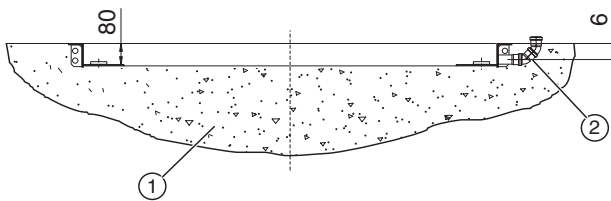

Natte put

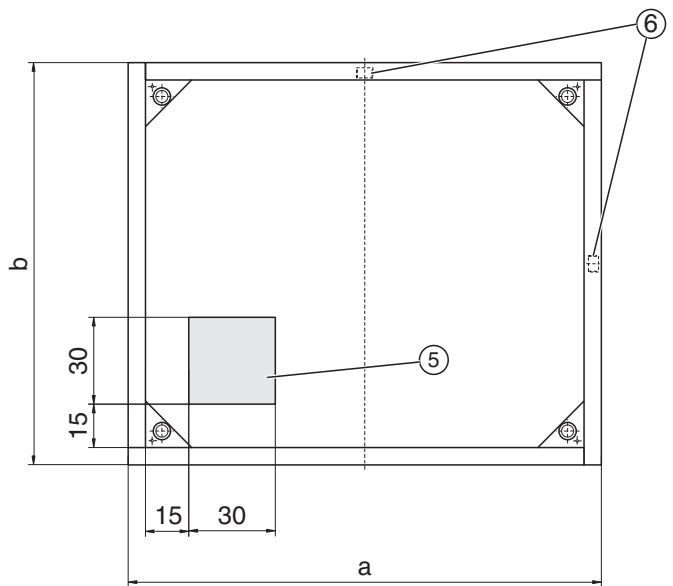
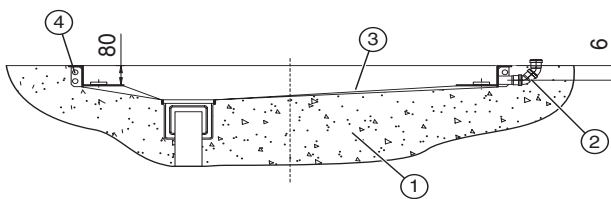

- 1 Betonsokkel, ca. 15 cm diep
- 2 Kabelkanaal, 2 x 45°
- 3 Afschot 4 % min.

- 4 Bevestigingsmogelijkheid voor metalen staven ter versterking
- 5 Locatie voor afvoer
- 6 2 x aansluitmogelijkheid kabelkanaal

nefton
Ζύγιση
Σήμανση
Συμμόρφωση

Νεύτων Τεχνολογίες ΑΒΕΕ

Γέρακα 113, Τ.Θ. 67934

15344 Γέρακας

Τηλ: 210 6654544

Fax: 210 6654545

marketing@nefton.gr

www.nefton.gr



22015843A

Subject to technical changes © Mettler-Toledo (Albstadt) GmbH 07/01 Printed in Germany 22015843A

Mettler-Toledo (Albstadt) GmbH

D-72458 Albstadt

Tel. ++49-7431-14 0, Fax ++49-7431-14 232

Internet: <http://www.mt.com>